

Via Remo Brambilla n. 2
20049 Concorezzo Milano
Tel. ++ 39 039 6040490
Fax ++ 39 039 6049961

E-mail: macchinespeciali@macchinespeciali.it
Internet: <http://www.macchinespeciali.it>

SPULENTABELLE (Auszug aus Normen DIN 46395)

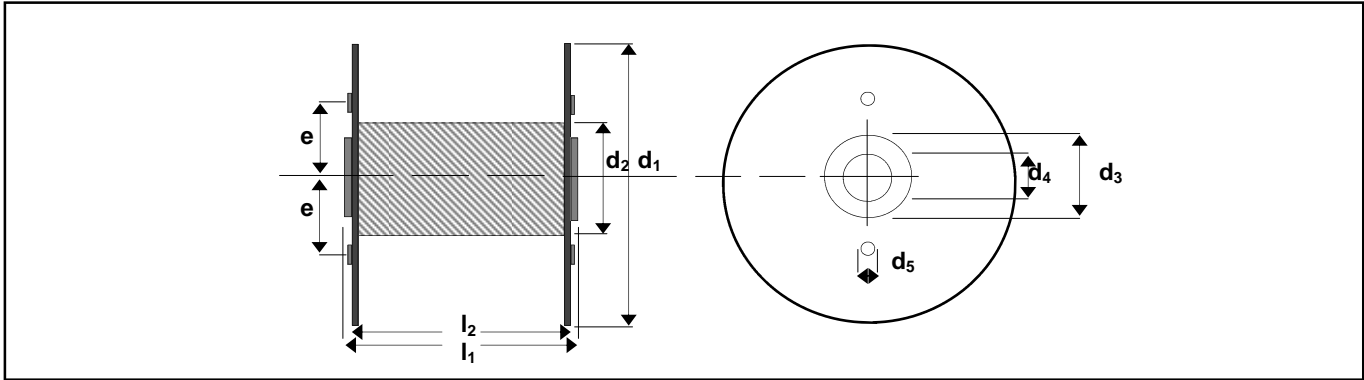

d_1 Flansch-Ø	d_2 Fass-Ø	d_3 Naben-Ø	d_4 Bohrungs-Ø			l_1 Breite max	l_2 Nutz- breite	Volumen in dm ³	Gewicht Kupferseil in Kg. c.a.	Gewicht Alu-Seil in Kg. c.a.		
				d_5 Ø Mitnehmer	e Radium Bohr. Mitnehmer							
100	40	50	28	8 bis 16	40	80	63	0,42	2,3			
125	50					95	80	0,83	4,6			
160	63					118	100	1,7	9			
200	80	71	36		71	150	125	3,3	17,5			
	100					125	100	2,35	13			
250	100					190	160	6,6	37	18,5		
315	125			150	125	4,6	26	13				
	160			236	200	13,1	74	37				
355	140			112	56	16 bis 28	112	190	160	9,2	52	26
	180	265	224					18,7	106	53		
215	180	13,2	75					37,5				
400	160	300	250				26,3	150	75,5			
	200	236	200				18,8	107	53,5			
450	180	335	280				37,4	215	107			
	224	265	224			26,8	154	77				
500	200	140	56			16 bis 28	140	375	315	51,9	295	147
	250							300	250	36,8	209	104
224	425							355	73,4	420	210	
560	280					335	280	51,7	296	148		
	250					475	400	105,1	600	300		
630	315			375	315	72,5	414	207				
710	355	160	80	28 bis 40	160	530	450	133,6	763	381		
800	400					600	500	188,5	1.000	500		
900	450					670	560	267,2	1.417	708		
1000	500					750	630	371,1	1.970	985		
1120	560					850	710	524,6	2.785	1.392		
1250	630			950	800	732,4	4.000	2.000				
1400	710			40 bis 63	100	300	1060	900	1029,1	5.620	2.810	
1600	800						1180	1000	1508,0	8.235	4.117	
1800	1000						1320	1120	1970,4	10.760	5.880	
2000	1120						1500	1250	2695,5	14.720	7.360	
2240	1250	1700	1400				3799,1	20.750	10.375			
2500	1500	1900	1600	5026,5	27.450	13.725						
2800	1800	2120	1800	6503,1	35.530	17.765						